

HONDA CMX1100 REBEL '21-

M O U N T I N G I N S T R U C T I O N S

REF 21461

SEMIFAIRING MIRAGE TOURING MODEL



ALLEN
Nº 3
Nº 6
Nº 8



En las revisiones del vehículo es conveniente efectuar también el mantenimiento de apriete de toda la tornillería del semicarenado, especialmente los tornillos que fijan éste al vehículo. Gracias por su atención.
It would be convenient to retight the semifairing screws, specially the ones that are fixed to the motorcycle, whenever you maintain the vehicle. Thanks for your attention.

ID	PIEZA/PART	DESCRIPCIÓN	DESCRIPTION	QTY	REF
1		Semicarenado Mirage	Mirage semifairing	1	10924N
2		Cúpula TOURING	TOURING screen	1	10926F/H/W
3		Soporte superior derecho (º)	Upper Right support (º)	1	SOPOR4P3SR21460
4		Soporte superior izquierdo (º)	Upper Left support (º)	1	SOPOR4P3SL21460
5		Soporte inferior derecho (º)	Lower Right support (º)	1	SOPOR4P3IR21460
6		Soporte inferior izquierdo (º)	Lower Left support (º)	1	SOPOR4P3IL21460
7		Tornillo Allen M8x45 Ø11 ISO 7380	M8x45 Ø11 ISO 7380 Allen screw	2	TORNI-I7380-817
8		Casquillo Ø8,5x Ø13 x12mm	Ø8,5x Ø13 x12mm spacer	2	CASQUI-M----769
9		Tornillo Allen M5x20 Ø11 ISO 7380	M5x20 Ø11 ISO 7380 Allen screw	2	TORNI-I7380-730
10		Casquillo Ø8,5x Ø13 x6	Ø8,5x Ø13 x6 spacer	2	CASQUI-----776
11		Silentblock M5	M5 silentblock	5	SILENBTM5-046/1
12		Arandela nylon M5x1	M5x1 nylon washer	5	ARNV00000000245
13		Tornillo Allen M5x16 Ø11 ISO 7380	M5x16 Ø11 ISO 7380 Allen screw	9	TORNI-I7380-493
14		Tapón tornillo M5 ISO 7380	M5 ISO 7380 screw cap	9	TAPON-----85
15		Silentblock Ø12xØ6x9	Ø12xØ6x9 silentblock	4	AROPASACABLES-1
16		Casquillo con valona Ø12xØ6,8x7,3	Ø12xØ6,8x7,3 Bush with flange	4	CASQUI-1A---750

HONDA CMX1100 REBEL '21-

INSTRUCCIONES DE MONTAJE - MOUNTING INSTRUCTIONS - MONTAGEANLEITUNG

1

DISASSEMBLY
DESMONTAJE

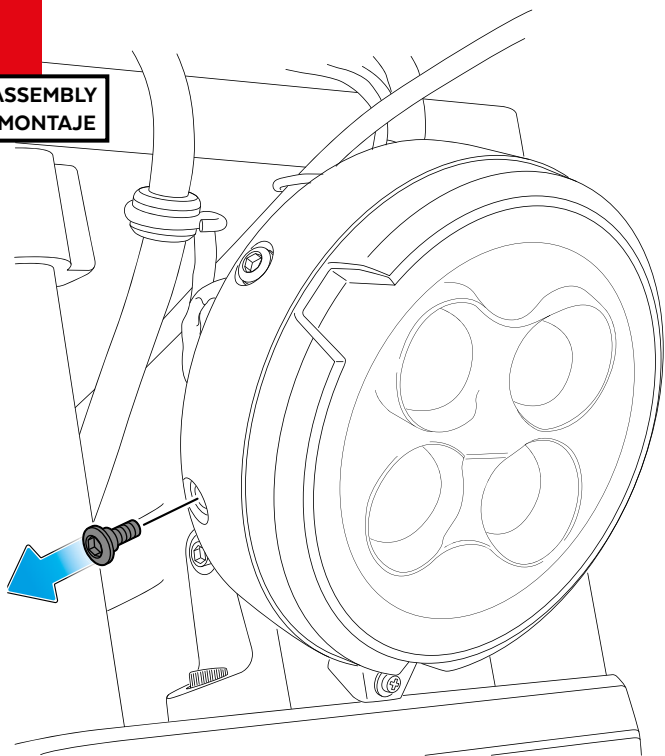

2

ASSEMBLY
MONTAJE

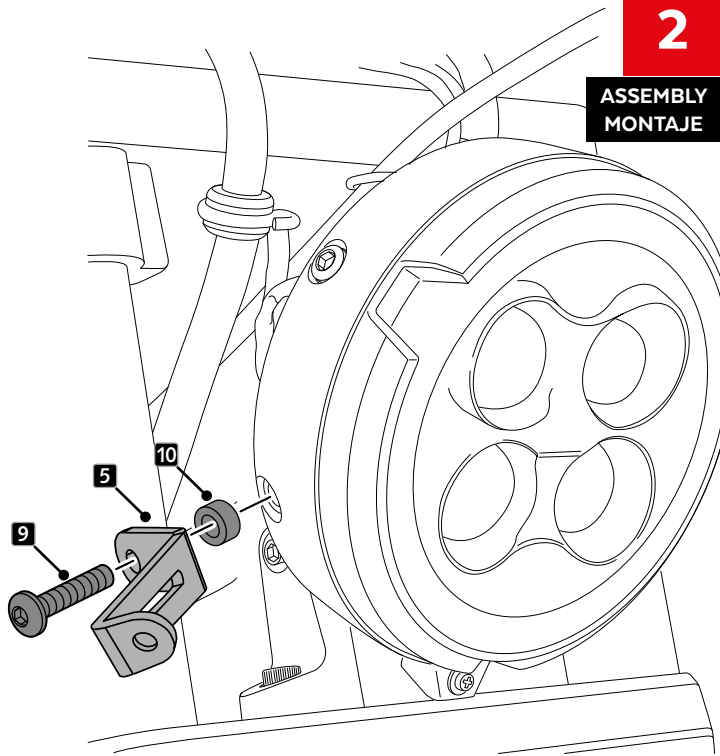

3

DISASSEMBLY
DESMONTAJE

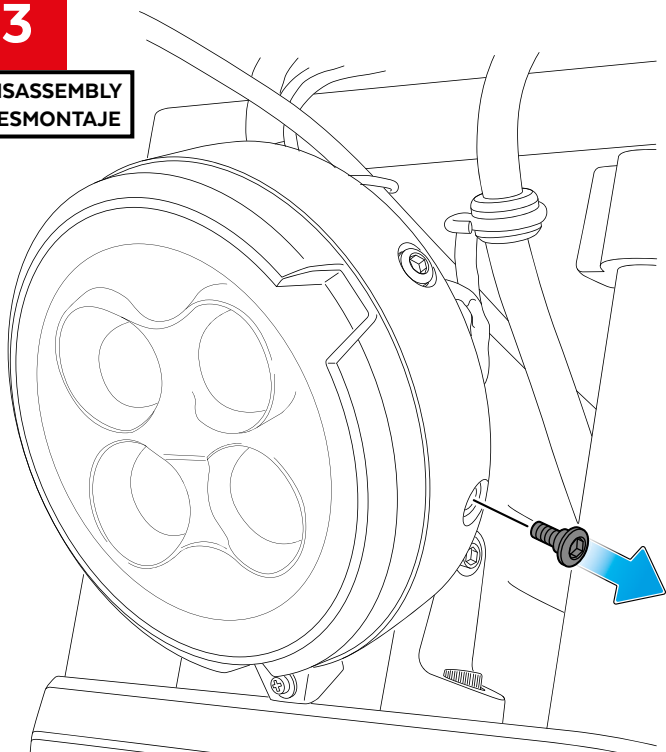

4

ASSEMBLY
MONTAJE

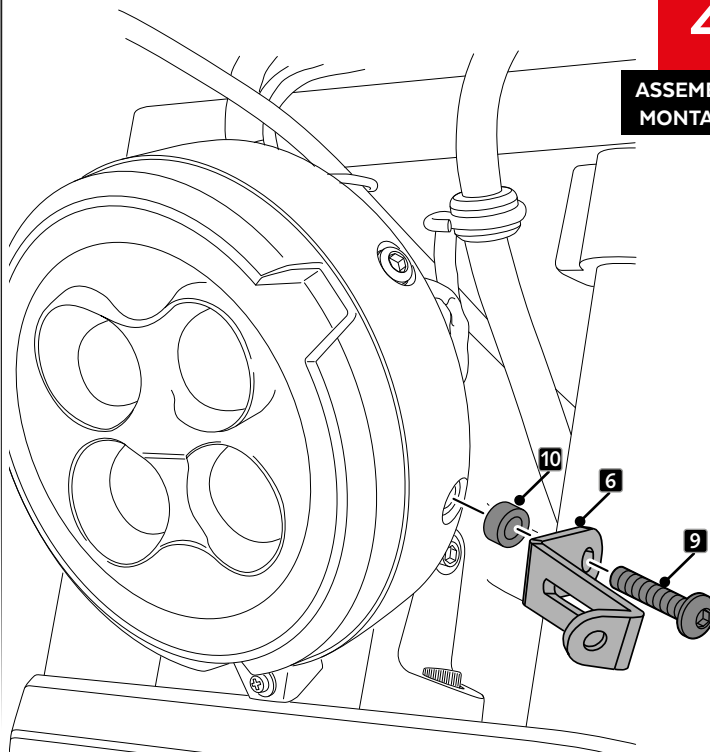

HONDA CMX1100 REBEL '21-

INSTRUCCIONES DE MONTAJE - MOUNTING INSTRUCTIONS - MONTAGEANLEITUNG

5

**DISASSEMBLY
DESMONTAJE**

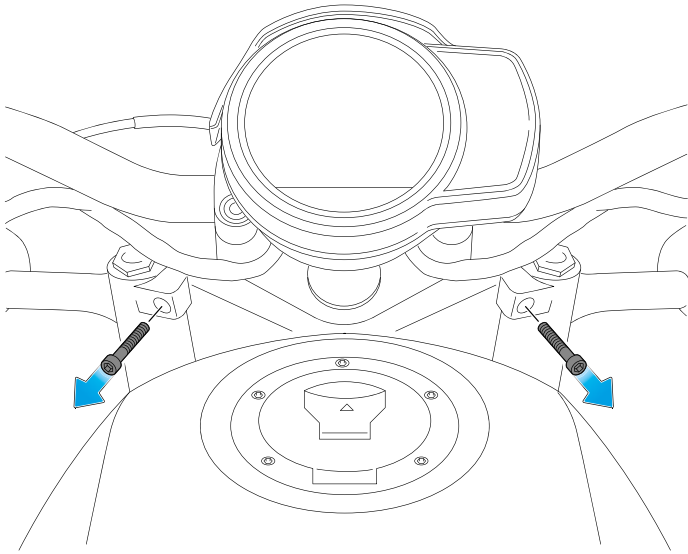

ID7



22 Nm - Par de apriete
22 Nm - Tightening torque

6

**ASSEMBLY
MONTAJE**

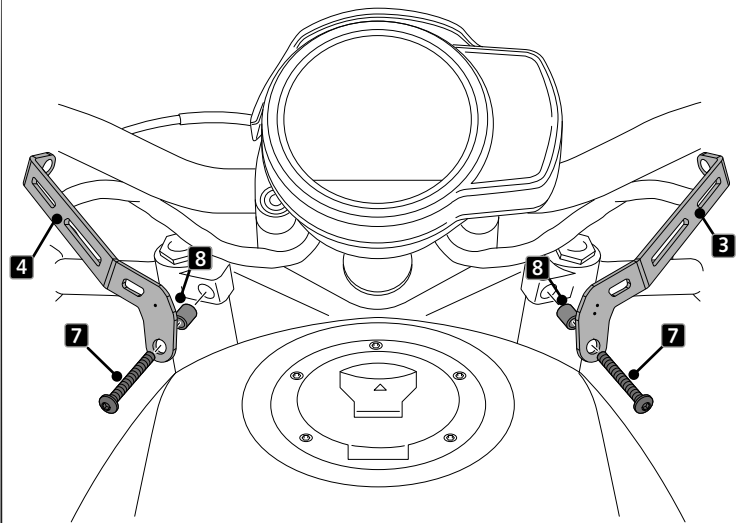

7

**ASSEMBLY
MONTAJE**



**DESPLAZAR INTERMITENTES ORIGINALES
MOVE ORIGINAL TURN SIGNALS**

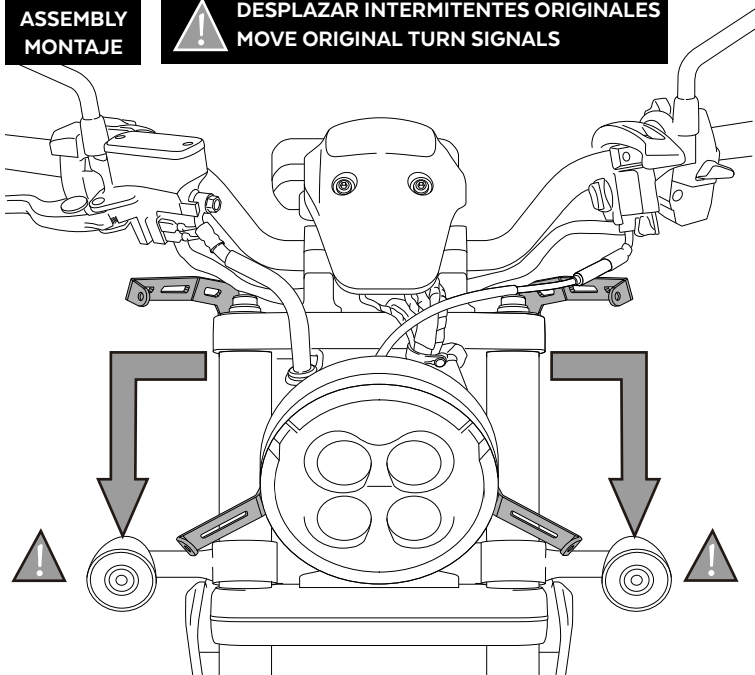

ID13



2,5 Nm - Par de apriete
2,5 Nm - Tightening torque

8

**ASSEMBLY
MONTAJE**

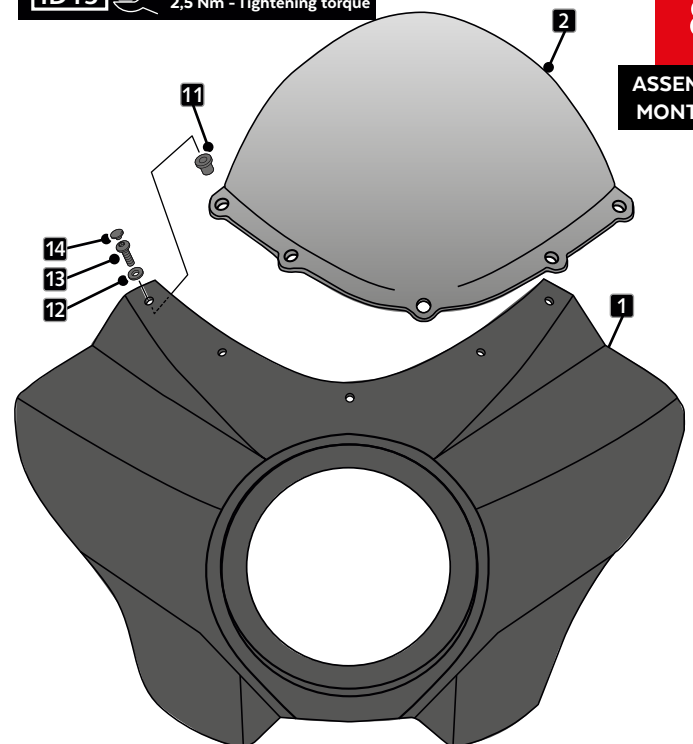



HONDA CMX1100 REBEL '21-

INSTRUCCIONES DE MONTAJE - MOUNTING INSTRUCTIONS - MONTAGEANLEITUNG

9

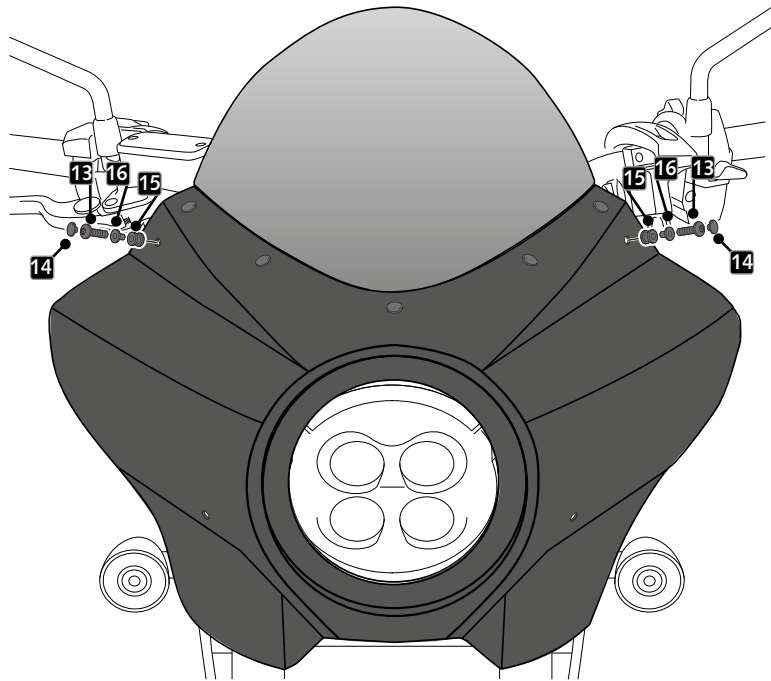
ASSEMBLY
MONTAJE



ID13  3 Nm - Par de apriete
3 Nm - Tightening torque

10

ASSEMBLY
MONTAJE

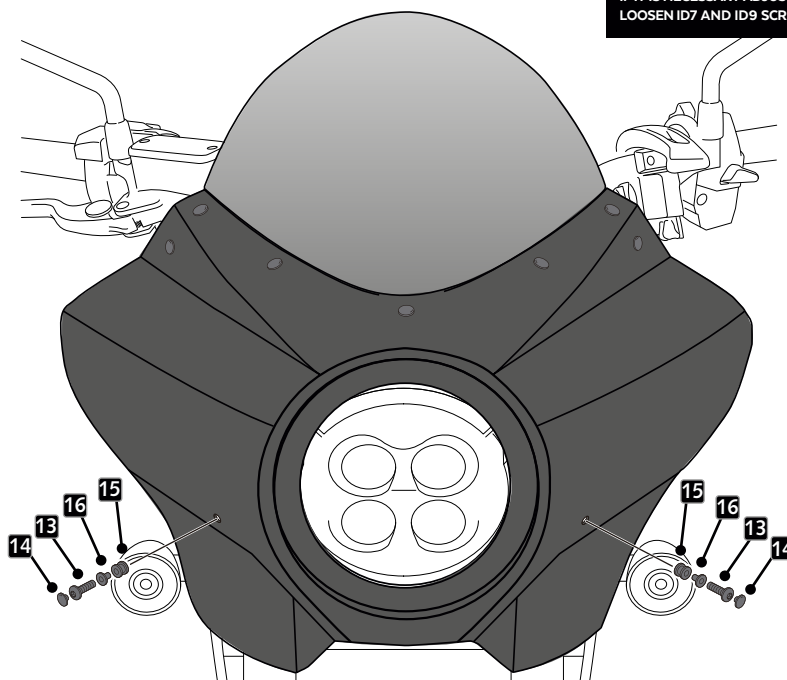

SI ES NECESARIO AJUSTAR LA POSICIÓN DEL SEMICARENADO,
AFLOJAR TORNILLOS ID9 Y ID7, Y AJUSTAR LA POSICIÓN DE LOS SOPORTES.

IF IT IS NECESSARY ADJUST THE POSITION OF THE SEMIFAIRING,
LOOSEN ID7 AND ID9 SCREWS AND ADJUST THE POSITION OF THE SUPPORTS.

ID13  3 Nm - Par de apriete
3 Nm - Tightening torque