

SPAAN

DAELIM DAYSTAR ENGINE GUARD MOUNTING



Set the top of the motor protector over the radiator to position it as shown in **Image 1**

The lower part of the motor protector will be attached to the front anchor of the platform support, on the inside (**Image 2**)

To anchor it, remove the screw that secures the platform support. In place the **M8x30** screw that comes in the **SPAAN** kit will be placed, tightening it until it begins to protrude through the inside of the holder. Aim the drill of the lower engine cover plates in that place. The screw will be tightened to the bottom, the motor protector being positioned. (**Image 3**). Put the self-locking nut of **M8** through the inside of the screw, without tightening it.

Adjust the position of the top of the motor protector to be able to hug the frame tube from inside to outside to pass its threaded ends through the holes in the plates. Fix it to these with the self-locking nuts of **M8**. (**Image 4**)

Once the upper part is fixed, tighten the nuts of the lower part.



Image 1

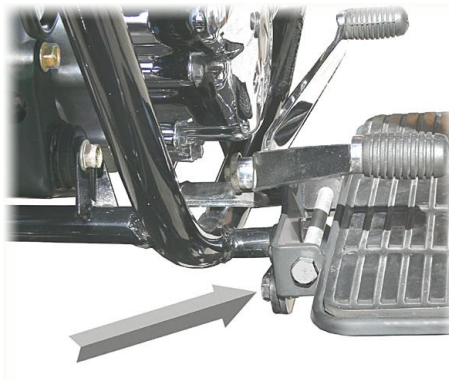

Image 2

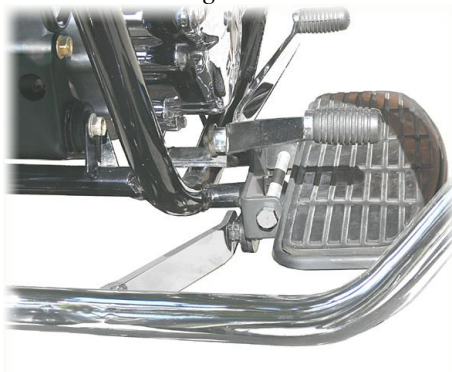

Image 3

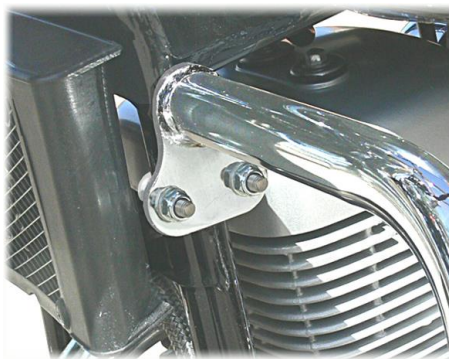

Image 4